

0597-L-21/1

4 January 2022

Test report

IP-Fix clip in combination with steel trapezoidal profile 35/1035



kiwa 

**Trust
Quality
Progress**



**Testing institute for
the building envelope**

expertise in façades and roofs



0597-L-21/1

4 January 2022

Test report

IP-Fix clip in combination with steel trapezoidal profile 35/1035

© 2022 Kiwa N.V.

All rights reserved.

No part of this report may be reproduced, stored in a database or retrieval system, or published, in any form or in any way, electronically, mechanically, by print, photoprint, microfilm or any other means without prior written permission from the publisher.

Kiwa BDA Testing B.V.

Avelingen West 35-37
P.O. Box 389
4200 AJ Gorinchem
The Netherlands

Tel. +31 183 669 690
testing@bda.nl
www.kiwabda.nl

Commercial register Registered
by Chamber of Commerce
Midden Nederland 23059445

Details

Principal

IMS Solar B.V.
Wognumsebuurt 10
NL-1817 BH ALKMAAR

Contact person

J. Haanen
j.haanen@ims-solar.com'

Email

3 December 2021

Date of order

Project number

0597-L-21/1

Author

A.R. Hameete

Subject

determination of the wind uplift resistance

All assignments accepted by Kiwa BDA Testing B.V. are subject to our general terms and conditions. The report may only be reproduced in full.

Contents

	Contents	1
1	Introduction	2
2	Construction of the test specimen	4
3	Investigation	5
4	Results of IP-Fix clip in combination with steel trapezoidal profile 35/1035	6
4.1	Calculation of the characteristic value of the wind uplift resistance (R_k)	8
4.2	Characteristic wind resistance	9
I	Photo report of the test and test results	
II	Drawings and photos of the products and further package data	

1 Introduction

By order of IMS Solar B.V., Kiwa BDA Testing B.V. has determined the wind uplift resistance of the **IP-Fix clip** in combination with **steel trapezoidal profile 35/1035** in portrait orientation.

The suppliers and the dates of delivery of the products used are mentioned below.

Table 1 – Specifications of the products used

Product	Supplier		Delivery date
	company	person	
Purlins	Kiwa BDA Testing B.V.	-	09-12-2021
Steel trapezoidal profile	IMS Solar B.V.	J. Haanen R. Schilderman	09-12-2021
Fasteners for steel trapezoidal profile	IMS Solar B.V.	J. Haanen R. Schilderman	09-12-2021
PV modules mounting system	IMS Solar B.V.	J. Haanen R. Schilderman	09-12-2021
PV modules	IMS Solar B.V.	J. Haanen R. Schilderman	09-12-2021

On the samples the following data were found.

Description rafter

- Product : purlins
- Producer : not revealed
- Dimensions : 120 mm × 55 mm
- Production code : not revealed

Description steel trapezoidal profile

- Product : steel trapezoidal profile 35 / 1035
- Producer : not revealed
- Dimensions : 2000 mm × 1035 mm × 0,75 mm
- Production code : not revealed

Description fasteners for steel sheet piling profile

- Product : corrugated sheet screws
- Producer : not revealed
- Dimensions : 7 mm × 90 mm
- Production code : not revealed

Description PV module

- Product : JKM360M-6TL3-V
- Producer : Jinko Solar Co. Ltd
- Dimensions : 1692 mm × 1029 mm × 30 mm
- Product code : JKM360M-6TL3-V
- Production code : not revealed

Description fastening system PV module

- Product : IP-Fix rivet
- Producer : IMS Solar B.V.
- Dimensions : 81 mm × 22 mm × 24,9 mm
- Product code : 34045
- Production code : not revealed

- Product : rivet
- Producer : IMS Solar B.V.
- Dimensions : Ø 6,3 mm
- Product code : 34045
- Production code : not revealed

- Product : IP-30 insert profile light
- Producer : IMS Solar B.V.
- Dimensions : 51,93 mm × 52,9 mm
- Product code : 14041
- Production code : not revealed

See annex II for photos and drawings of the products and further package data.

2 Construction of the test specimen

On 9 December 2021 the test specimens have been built up by Mr J. Haanen and Mr R. Schilderman of IMS Solar B.V. and Mr J.D. Maestre Rocha and Mr A.R. Hameete of Kiwa BDA Testing B.V.

The test specimens have been built up according to the prescription of IMS Solar B.V. from the bottom up.

- Substructure : structure of three wooden purlins, dimensions: 120 mm × 55 mm, with a centre to centre spacing of 970 mm.
- Trapezoidal profiles : on top of the purlins two steel trapezoidal profiles, type 35/1035, have been placed, dimensions 2000 mm × 1035 mm, each profile fixed with twelve fasteners, dimensions 7 mm × 90 mm.
- Mounting system : six IP-Fix clips (two rows of three clips) have been positioned and fixed. The mutual centre to centre spacing of the clips has been set at 1707 mm in vertical direction and at 750 in the horizontal direction. On the clips two insert profiles (light), length 2200 mm, have been fixed in horizontal direction.
- PV modules : in between the two horizontal positioned insert profiles two PV modules (JKM360M-6TL3-V), dimensions 1692 mm × 1029 mm, have been positioned in portrait orientation.

3 Investigation

The determination of the wind uplift resistance has been performed in accordance with the requirements in:

- EN 14437:2004 – Determination of the uplift resistance of installed clay or concrete tiles for roofing – Roof system test method.
- NEN 7250:2014 – Zonne-energiesystemen – Integratie in daken en gevels – Bouwkundige aspecten¹.

The determination of the wind uplift resistance has been performed on a system containing two PV modules in combination with two insert profiles and six IP-Fix clips on a substructure of steel trapezoidal profiles. The PV modules have been laid in portrait position. The loading of the two PV modules has been applied by using eight suction cups per PV module.

The wind uplift resistance has been determined in triplicate. The test has been performed at a slope of 45°. Preceding the actual tests an exploratory pre-test was performed to obtain an indication of the strength of the system and the corresponding collapse image.

According to NEN 7250 the system is considered to be collapsed when one of the following occurs.

- Collapse of the mechanical fixing on to the structure.
- Pulling out or breakage of any part of the installation kit of the product which is tested.
- Breakage of product which is tested.
- The displacement of any part exceeds the maximum of 100 mm.
- The remaining displacement of any roofing element after releasing the force to zero exceeds 5 mm.
- The product which is tested gets loose from the substructure.
- The remaining displacement of any roofing element after releasing the force to zero degrades the weathertightness of the roof.

By request of the principal the displacement has been measured at the following points:

Measuring points at the upper side of the test specimen

- MU = at the middle clip of the upper profile;
- RU = at the right clip of the upper profile;
- LL = at the left clip of the lower profile;
- ML = at the middle clip of the lower profile.

On 9 December 2021 the tests have been performed in the laboratory of Kiwa BDA Testing B.V. by Mr J.D. Maestre Rocha of Kiwa BDA Testing B.V. in the presence of Mr J. Haanen and Mr R. Schilderman of IMS Solar B.V.

In annex I a photo report of the test and the test results is given.

¹ Solar energy systems – Intergration in roofs and facades – Building aspects.

4 Results of IP-Fix clip in combination with steel trapezoidal profile 35/1035

Table 2 – IP-Fix clip in combination with steel trapezoidal profile 35/1035, test 1

Force [N]	Movement [mm]							
	MU		RU		LL		ML	
	maximum displacement	remaining displacement	maximum displacement	remaining displacement	maximum displacement	remaining displacement	maximum displacement	remaining displacement
0	0	0	0	0	0	0	0	0
6000	12,00	1,30	11,50	1,80	7,60	1,50	4,70	1,20
6400	13,00	1,40	12,60	2,10	8,40	1,60	5,60	1,30
6800	13,80	1,60	13,50	2,30	9,10	1,70	6,20	1,40
7200	14,90	1,80	14,80	2,60	10,00	1,80	7,10	1,60
7600	15,80	2,00	15,70	2,80	10,70	1,80	7,90	1,60
8000	16,90	2,20	16,90	3,10	11,60	1,90	8,70	1,70
8400	18,10	2,60	18,20	3,40	12,50	2,00	9,70	1,90
8800	- ²⁾	- ²⁾	79,10 ¹⁾	10,10 ¹⁾	- ²⁾	- ²⁾	- ²⁾	- ²⁾

¹⁾ At the applied force of 8800 N the PV modules have been pulled out of the insert profile; consequently the ultimate failure has been reached.
²⁾ Due to the force in which the PV modules had been detached from the insert profile, the sensors moved from their original place; consequently no data were listed.

Table 3 – IP-Fix clip in combination with steel trapezoidal profile 35/1035, test 2

Force [N]	Movement [mm]							
	MU		RU		LL		ML	
	maximum displacement	remaining displacement	maximum displacement	remaining displacement	maximum displacement	remaining displacement	maximum displacement	remaining displacement
0	0	0	0	0	0	0	0	0
6000	12,80	1,80	11,70	2,40	- ³⁾	- ³⁾	6,70	1,70
6400	13,70	2,00	12,90	2,70	- ³⁾	- ³⁾	7,10	1,80
6800	14,40	2,00	14,10	3,00	- ³⁾	- ³⁾	8,00	1,80
7200	15,40	2,40	15,40	3,60	- ³⁾	- ³⁾	9,00	2,00
7600	- ²⁾	- ²⁾	80,00	- ²⁾	- ³⁾	- ³⁾	- ²⁾	- ²⁾

¹⁾ At the applied force of 7600 N the PV modules have been pulled out of the insert profile; consequently the ultimate failure has been reached.
²⁾ Due to the force in which the PV modules had been detached from the insert profile, the sensors moved from their original place; consequently no data were listed.
³⁾ Displacement cannot be measured due to a broken sensor.

Table 4 – IP-Fix clip in combination with steel trapezoidal profile 35/1035, test 3

Force [N]	Movement [mm]							
	MU		RU		LL		ML	
	maximum displacement	remaining displacement	maximum displacement	remaining displacement	maximum displacement	remaining displacement	maximum displacement	remaining displacement
0	0	0	0	0	0	0	0	0
6000	10,40	0,80	9,60	1,00	- ³⁾	- ³⁾	5,70	1,20
6400	11,40	1,00	10,60	1,10	- ³⁾	- ³⁾	6,50	1,30
6800	12,10	1,20	11,30	1,30	- ³⁾	- ³⁾	7,10	1,40
7200	12,80	1,20	12,20	1,50	- ³⁾	- ³⁾	7,80	1,50
7600	13,70	1,50	13,20	1,90	- ³⁾	- ³⁾	8,60	1,70
8000	14,90	1,90	14,60	2,30	- ³⁾	- ³⁾	9,50	1,90
8400	- ²⁾	- ²⁾	82,60	- ²⁾	- ³⁾	- ³⁾	78,10	- ²⁾

¹⁾ At the applied force of 8400 N the PV modules have been pulled out of the insert profile; consequently the ultimate failure has been reached.
²⁾ Due to the force in which the PV modules had been detached from the insert profile, the sensors moved from their original place; consequently no data were listed.
³⁾ Displacement cannot be measured due to a broken sensor.

4.1 Calculation of the characteristic value of the wind uplift resistance (R_k)

The calculation of the characteristic value according to NEN 7250 is mentioned below.

Table 5 – Results

Results		
Test specimen	collapse force $R_{r,i}$ [N]	uplift resistance R_x [N]
1	8800	8400
2	7600	7200
3	8400	8000

The mean value and the standard deviation of the resistance from all tests have been calculated by:

$$R_x = \frac{1}{n} \sum R_{r,i}$$

$$s_x^2 = \frac{1}{n-1} \sum (R_{r,i} - R_x)^2$$

Where:

R_x = is the mean uplift resistance

$R_{r,i}$ = is the force preceding the force at which one of the mentioned collapse events occurs

n = the number of tests that has been performed

Table 6 – Values for the k_n factor dependent on the number of tests (n)

n	3	5	7
k_n	3,37	2,33	2,08

The characteristic value of the wind uplift resistance has been calculated by:

Table 7 – Mean Value for the R_x factor dependent on the number of tests (n)

The mean value of the wind uplift resistance from all tests		
R_x sum [N]	n	R_x [N]
23600	3	7867

4.2 Characteristic wind resistance

Table 8 – Standard deviation of the wind uplift resistance

Standard Deviation [N]	
s ($\sigma_{(n-1)}$)	611

The characteristic value of the wind uplift resistance has been calculated by:

$$R_k = R_x - k_n s_x$$

Where:

R_k = the characteristic value of the wind uplift resistance

k_n = the factor depending on the number of tests

R_x = the mean value of the wind uplift resistance from all tests

s_x = the standard deviation of the wind uplift resistance from all tests

Table 9 – Characteristic value of the wind resistance.

Characteristic value of the wind uplift resistance		
R_x [N]	k_n	s_x
7867	3,37	611
R_k [N]		5808

Remarks:

The results are only related to the investigated samples, products and/or systems. Kiwa BDA Testing B.V. is not liable for interpretations or conclusions that are made in consequence of the results obtained.

The uncertainty of measurement can be retrieved at Kiwa BDA Testing B.V.

If sampling was not performed by Kiwa BDA Testing B.V., no judgement can be given with regard to the origin and representativeness of the samples.

Gorinchem, 4 January 2022
The laboratory

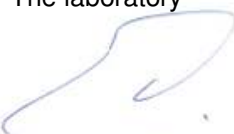

A.R. Hameete
operational manager

Kiwa BDA Testing B.V.



N.W.J. Haanappel BSc
manager testing

I Photo report of the test and test results

Photo 1
Overview of the substructure.



Photo 2
The trapezoidal sheets have been fixed on the purlins and six clips have been fixed to the trapezoidal sheet.

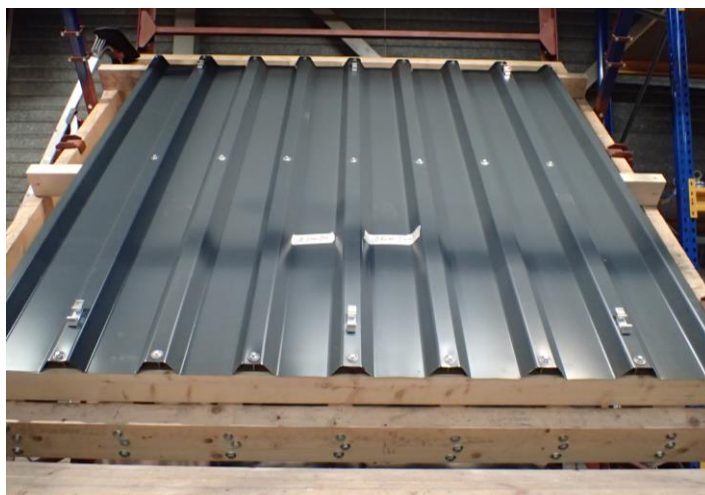

Photo 3
Detail of a IP-Fix clip fixed with a rivet.



Photo 4
Detail of a rivet on the
backside of the
trapezoidal sheet.



Photo 5
Two insert profiles have
been fixed to the IP-Fix
clips.



Photo 6
Detail of the fixation
between the IP-Fix clip
and the insert profile.

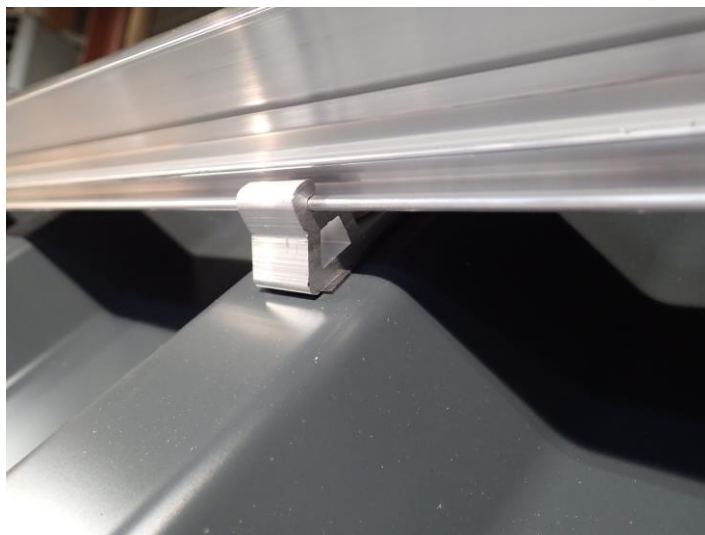

Photo 7
Detail of the fixation
between the IP-Fix clip
and the insert profile.

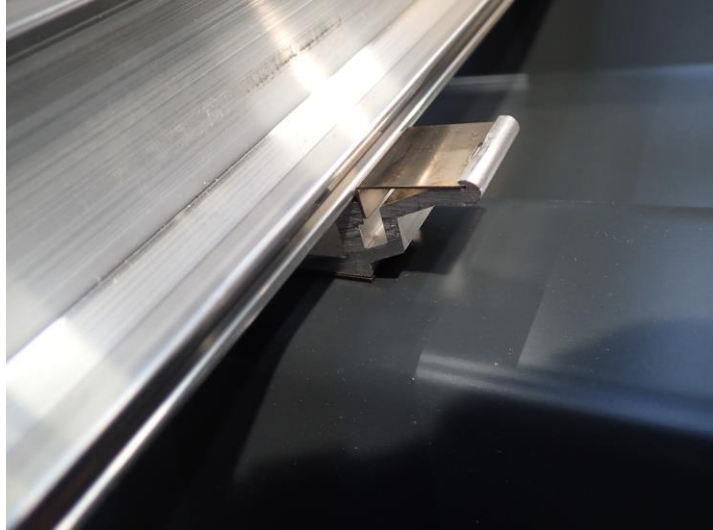

Photo 8
The PV modules have
been positioned in the
insert profiles.



Photo 9
The suction cups are
placed in position and
test specimen 1 is ready
for testing.



Photo 10
Detail of the failure mode
of test specimen 1.



Photo 11
The suction cups are
placed in position and
test specimen 2 is ready
for testing.

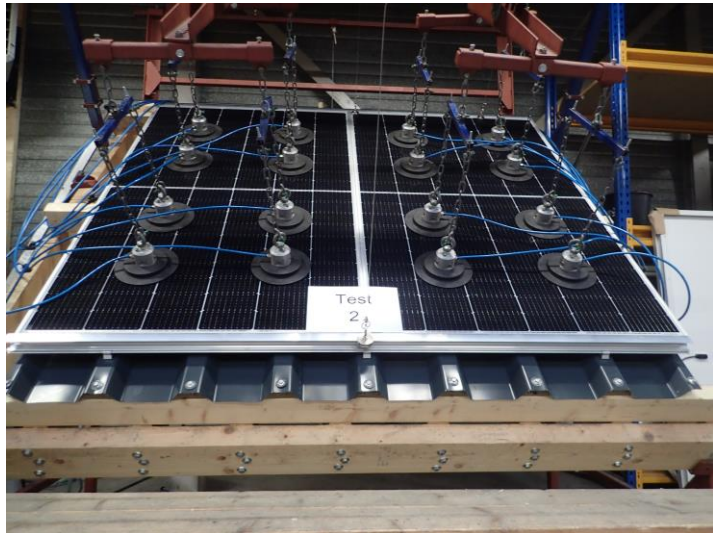

Photo 12
Detail of the failure mode
of test specimen 2.

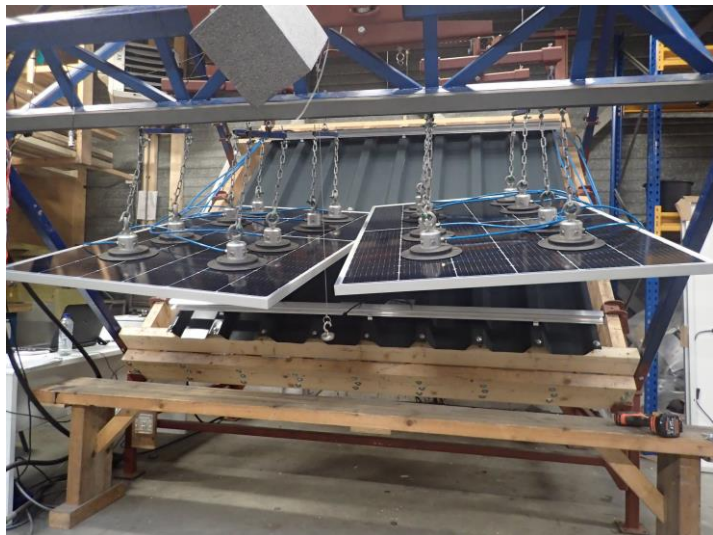

Photo 13
The suction cups are placed in position and test specimen 3 is ready for testing.

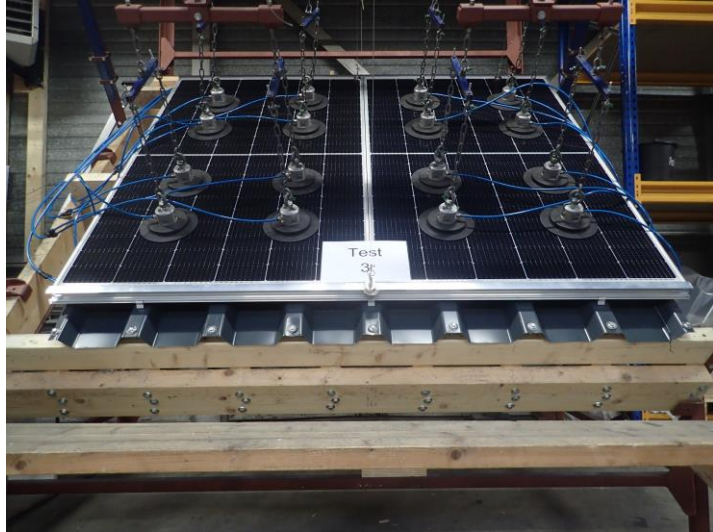
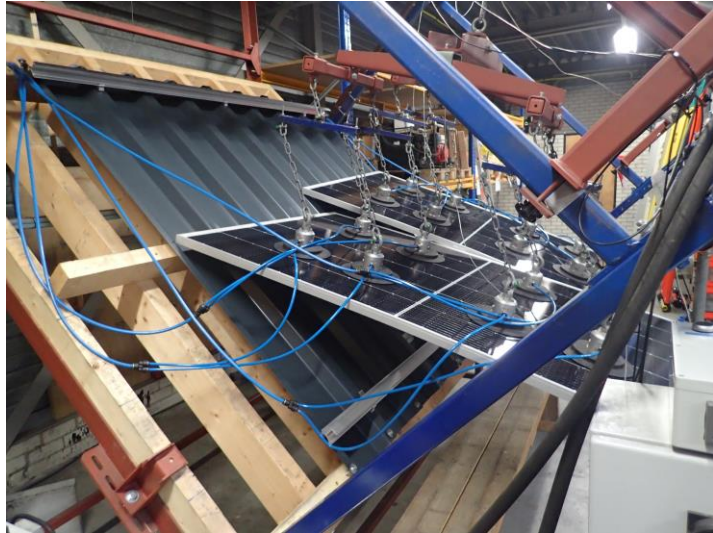

Photo 14
Detail of the failure mode of test specimen 3.



II Drawings and photos of the products and further package data

PV modules





Jinko Solar Co., Ltd.
 NO.1 Jinko Road Shangrao Economic Development Zone
 Jiangxi Province 334100 China
 www.jinkosolar.com

PHOTOVOLTAIC MODULE
 Made in China

Solar Module Type: JKM360M-6TL3-V

Maximum Power(Pmax)	360W
Power Measurement Tolerance	± 3%
Maximum Power Voltage(Vmp)	33.24V
Maximum Power Current(Imp)	10.83A
Open Circuit Voltage(Voc)	39.91V±3%
Short Circuit Current(Isc)	11.64A±4%
Maximum System Voltage	1500VDC
Maximum Series Fuse Rating	20A
Operating Temperature	-40°C~+85°C
Protection Class	II
Fire Class	C
Weight	19.0(kg)
Dimension	1692×1029×30(mm)
STC: 1000W/m ² , AM1.5, 25°C	



WARNING

ONLY qualified personnel should install or perform maintenance work on these modules
BE AWARE of dangerous high DC voltage when connecting modules
DO NOT damage or scratch the rear surface of the module
 The modules meet the 2016 version of the standards



E3

PV modules mounting system

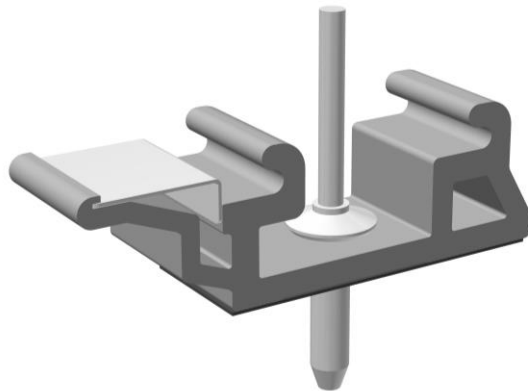
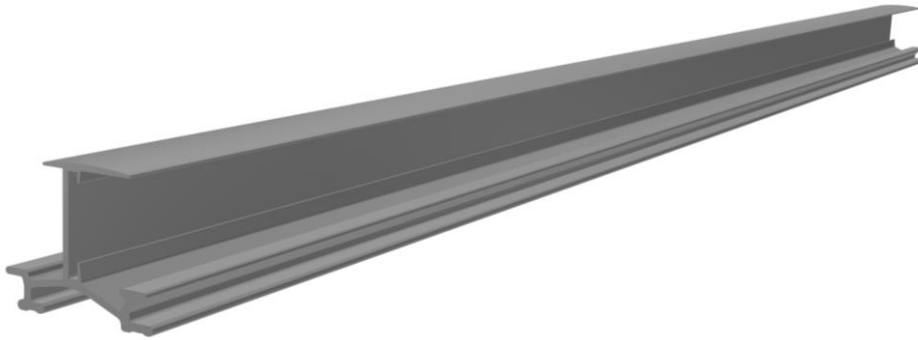



Fasteners for trapezoidal sheet



Trapezoidal sheet





Installation manual



Simple, reliable and easy to install in 5 steps on a steel roof

- 1 Measure, stake out and drill
- 2 Riveting IP-fix
- 3 Click IP insert profiles
- 4 Click cable bracket and opti bracket
- 5 Insert solar panels

Index

1. General installation conditions	03	2. Parts overview	06
<ul style="list-style-type: none"> ■ General information ■ Stability and conditions of the roof ■ Safety warnings ■ Coverage of application in the Netherlands ■ Wind load ■ Standards, regulations and legislation ■ Removal and disassembly ■ Warranty ■ Liability 	<ul style="list-style-type: none"> 03 03 04 04 05 05 05 05 05 	<ul style="list-style-type: none"> ■ Tools required ■ Installation ■ Step 1: Measure, stake out and drill ■ Step 2: Riveting IP-fix ■ Step 3: Click IP insert profiles ■ Step 4: Mounting cable bracket and opti bracket ■ Step 5: Insert solar panels 	<ul style="list-style-type: none"> 07 07 08 08 09 09 10

Simple, reliable and easy to install in 5 steps on a steel roof

- 1 Measure, stake out and drill
- 2 Riveting IP-fix
- 3 Click IP insert profiles
- 4 Click cable bracket and opti bracket
- 5 Insert solar panels

Index

1. General installation conditions	03	2. Parts overview	06
<ul style="list-style-type: none"> ■ General information ■ Stability and conditions of the roof ■ Safety warnings ■ Coverage of application in the Netherlands ■ Wind load ■ Standards, regulations and legislation ■ Removal and disassembly ■ Warranty ■ Liability 	<ul style="list-style-type: none"> 03 03 04 04 05 05 05 05 05 	<ul style="list-style-type: none"> ■ Tools required ■ Installation ■ Step 1: Measure, stake out and drill ■ Step 2: Riveting IP-fix ■ Step 3: Click IP insert profiles ■ Step 4: Mounting cable bracket and opti bracket ■ Step 5: Insert solar panels 	<ul style="list-style-type: none"> 07 07 08 08 09 09 10

Safety warnings

- Installation should be carried out by qualified technical constructors.
- Before starting installation the roof should be clean, dry etc.
- Should installation take place at a slanted roof please make sure to use fall protection materials such as edge protection and safety nets.
- If the surface of the roof is slippery due to rain or there is a strong wind, please avoid installation!
- It is recommended to follow the drawings in detail. Omitting or adding parts at your discretion may negatively affect the functioning of the mounting system and is therefore strongly discouraged!
- Chlorine fumes, aggressive fumes and fumes from rotting fruit can affect the durability of the rivets. IMS-Solar recommends choosing a different mounting method if these vapors are present.
- Place rubber fuses at the top between the panels if the slope of the panels is less than 10 degrees. With less slope, the pressure underneath is less; this prevents movement.
- Always wear appropriate protective shoes and clothing.
- Always wear work gloves for protection. Also to avoid damage to the solar panels; don't hold them without gloves.
- Never stand in a gutter!
- Use a lifting aid/lift installation to move materials.
- Use of a ladder should always take place on a solid surface and should be placed at an angle of 75 degrees, about one meter sticking out above the roof edge. Secure the top of the ladder by using a rope or fastener if possible.
- Please make sure to be informed about the last developments by checking the most recent version of the manual and guarantees.

Coverage of application in the Netherlands

- Solar panels: of all brands and models with a frame height of 30 or 35 mm.
- Wind zones: 1 to 3, terrain category II en III (NEN 1991-1-4).
- Roof height: 3 - 15 m. Should the roof be higher please contact your supplier.
- Type of roof: corrugated roof.
- Slope of the roof: between 15 - 60 degrees (35 degrees will be optimal).



Terrain category 0
Sea or coastal area with winds coming over the open sea.



Terrain category II
Area with low vegetation such as grass and freestanding obstacles (trees, buildings) with a spacing of at least 20 obstacle heights.



Terrain category III
Area with regular vegetation or buildings or isolated obstacles with spacing of no more than 20 obstacle heights (such as villages, suburban terrain, permanent forest).

Windload

Due to the influence of the wind, the distance of the solar panels to the top and bottom of the roof is at least 30 cm. The same applies for the distance of the solar panels to both sides of the roof. Please do not place solar panels partly or entirely within this area! Also think about sufficient room to move for maintenance work.

Standards, regulations and legislation in the Netherlands

To prevent accidents it's important to follow the mounting manual and regulations. Please pay attention to the below norms, regulations and legislation.

- **NEN 7250:2014** Constructive aspects solar-energy systems
- **NEN-EN 1990** Basis of the constructive design
- **NEN-EN 1991-1-3** General weight: snow
- **NEN-EN 1991-1-4** General weight: wind
- **NEN 1010:2015** Electrical installations for low voltage (HD-IEC 60364)
- **NEN-EN-IEC 62305** Lightning protection
- **Arbowet en Arboregeling** Safety labour and social affairs
- **NEN 3140** Safety management low voltage installations
- **Checklist VCA** Safe operation at location
- **Regulations scaffolds and ladders**

Removal and disassembly

Removal of the products accordingly to local laws and regulations

Warranty

Warranty according to the general conditions of IMS-Solar BV can be found at www.ims-solar.com.

Liability

IMS-Solar BV shall not be held liable for any damage or injury caused by a failure to not (strictly) comply with our safety regulations and instructions in this manual or due to negligence during installation our product and/or any involved accessories.

2. Parts overview



■ **14031** IP-30 insert profile 6,2m
Dimensions: 6200 x 52,9 x 51,93



■ **14032** IP-30 insert profile black 6,2m
Dimensions: 6200 x 52,9 x 51,93



■ **14051** IP-35 insert profile 6,2m
Dimensions: 6200 x 52,9 x 56,93



■ **14052** IP-30 insert profile black 6,2m
Dimensions: 6200 x 52,9 x 56,93



■ **14041** IP-30 insert profile light 6,2m
Dimensions: 6200 x 52,9 x 44,8



■ **14042** IP-30 insert profile light black 6,2m
Dimensions: 6200 x 52,9 x 44,8



■ **14061** IP-35 insert profile light 6,2m
Dimensions: 6200 x 52,9 x 49,8



■ **14062** IP-35 insert profile light black 6,2m
Dimensions: 6200 x 52,9 x 49,8

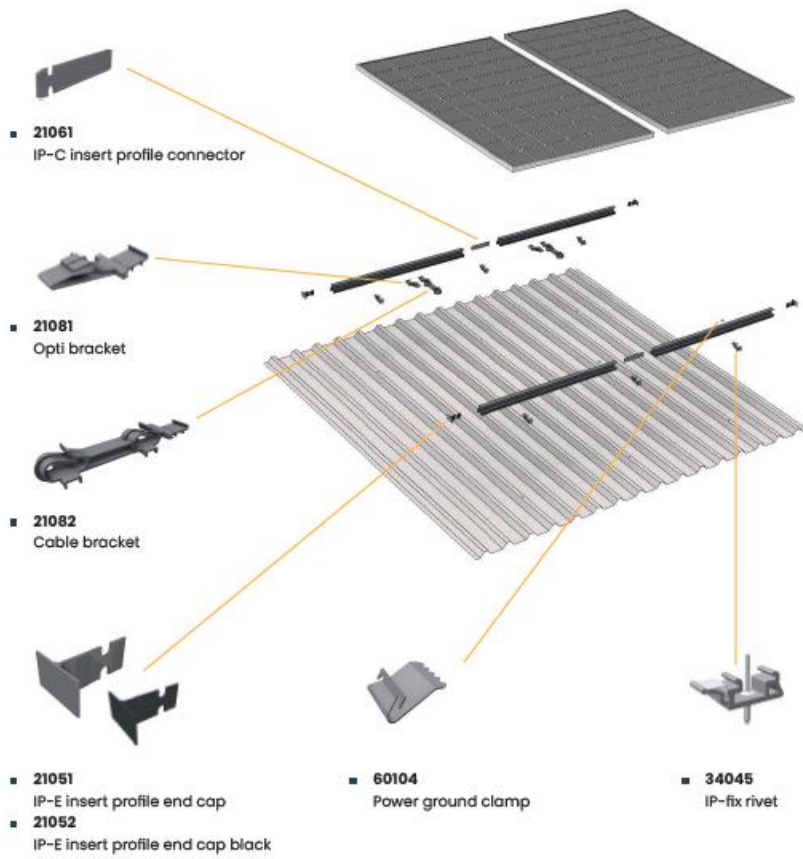

- **60101**
Use the IMS mounting tool for securing various parts. Make sure you use the right movement as described; upwards or downwards.



3. Installing IMS-Solar

Tools required



Drillmaster



Riveting tool



IMS mounting tool



Pencil



Measure tape

Installation

Before installing the mounting materials the roof sheets need to be cleaned with a brush. Remove algae, moss and debris to reduce unevenness during the installation. The position of the roof compared to the sun is essential to receive optimal results. Surrounding buildings or trees can create shade, which will have a negative effect on the result and efficiency of the solar panels. Therefore, check the surroundings in advance.

This manual is only suitable for unisolated and isolated steel roofs.

In preparation, it is important to adjust the drill size (mold) to the size of the solar panel + 17.7 mm (module size). Use of the mold is advised to prevent the drill from slipping. It is important that the rubber rings on the cross joint are adjusted so that they rest on a raised rib of the roof. This protects both the roof and the drilling mold from damage during installation.

The drill guide on the right side must be aligned so that the position of the drill hole is above the horizontal center of the raised rib of the trapezoidal sheet. The vertical spacing between the drill holes is the vertical height of the solar panel + 17.7 mm.

Step 1. Measure, stake out and drill

As indicated earlier, it is important that the distance of the solar panels to the top and bottom of the roof is at least 30 cm. The same applies for the distance of the solar panels to both sides of the roof. It is important to first check the carrying capacity of the substructure. After that, the module field can be measured based on the outcome of the IMS calculation program. Mark the positions of the first and last IP fix on the bottom row.

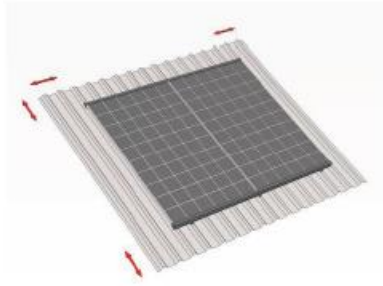

Use the drilling mold to determine the exact position and prevent the drill from slipping. The drill size is 6.5 mm; with this size the first and last IP fix on the bottom row are pre-drilled.

Place the positioning pins in the first and last drilled hole and stretch a string between them. This indicates the bottom row of IP fix. Now the mounting points on the raised ribs can be marked in the correct position.

Insert the positioning pin through the drilling mold into the pre-drilled hole of the bottom row of IP-fix; this allows you to move from position to position both vertically and horizontally, so that the exact location of the drill-hole can be determined and drilled. Horizontally it is important to first determine the position of the first and last raised rib in order to stretch a string between them as well.





Step 2. Riveting IP-fix

Rive the IP-fix into the pre-drilled holes. It is important that the metal spring is pointing upwards. For mounting the IP-fix, use the rubber underlay, the rivet and a cordless riveting tool. The rivet and IP-fix are mounted using the riveting tool.

It is important to use a rivet nose piece for the IMS-Solar sealing rivets.



Step 3. Click IP insert profiles

When all IP-fix are mounted, the horizontal IP insert profiles can easily be clicked into place from top to bottom with the wider part of the front always pointing downwards.

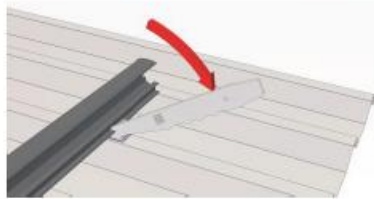
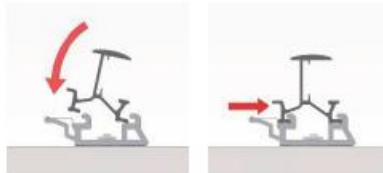

If the setup is wider than 6 meters, the IP insert profiles must be connected to each other with the IP-C insert profile connector. This is pushed in from the side halfway between the raised edges in the already mounted profile. Then secure it on one side by making the correct movement upwards with the mounting tool (make sure that this lock is on the same side in all connections).

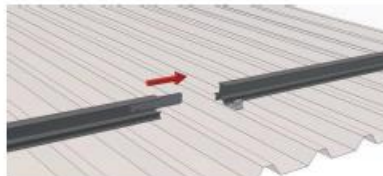

The next IP insert profile slides over the protruding part of the IP-C insert profile connector in such a way that a space of at least 5 mm between the two IP insert profiles remains open. This allows the IP insert profile to expand with heat and contract with cold. The system can continue to carry the load of the module without too much stress being applied.

Prevent the rails from sliding due to heat or cold by securing the IP-fix in the IP insert profile. Use the mounting tool to bend the IP insert profile, both left and right of the IP-fix, by moving downwards.

Then the IP-E insert profile end caps can be mounted. Slide it in from the side between the raised edges until it can go no further. Secure the IP-E insert profile end caps by moving the mounting tool upwards.

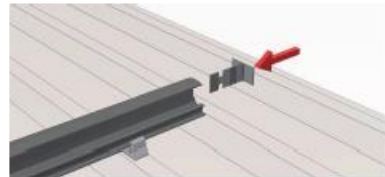

Step 4. Mounting cable bracket and opti bracket

Install cable bracket

- Click the cable bracket onto the IP insert profile by first hooking it onto the back and then clicking it upwards at the front.
- Slide the cables into the conductor, the 'plus' into one and the 'minus' into the other. Fasten with the ty-raps.

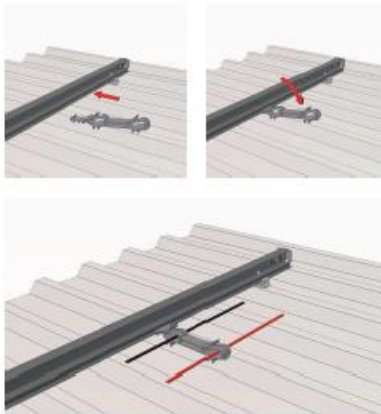

Install opti bracket

- Click the opti bracket onto the IP insert profile by first hooking it to the back and then clicking it upwards at the front.
- Click the optimizer onto the bracket.
- Connect the optimizer.

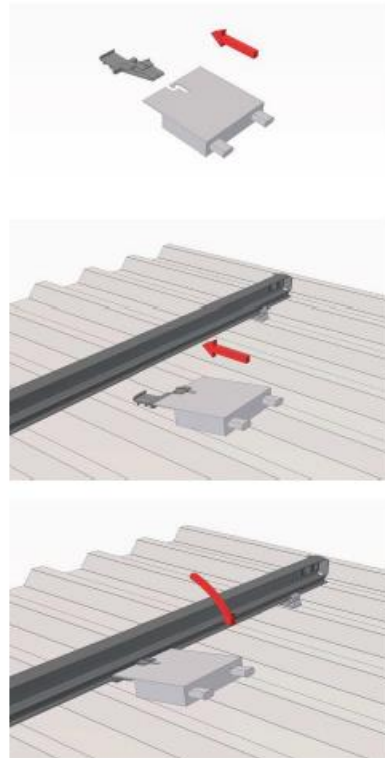

Step 5. Insert solar panels

When all IP insert profiles are attached, the solar panels can be inserted. Make sure that one power ground clamp is slid onto the IP insert profile to ground each solar panel.

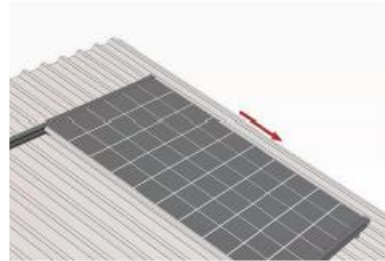
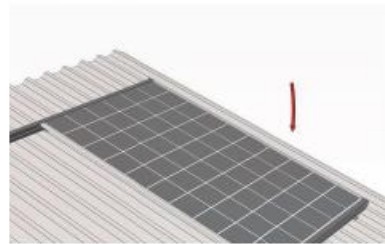
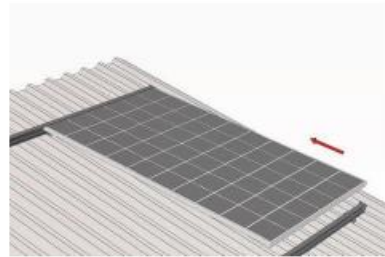
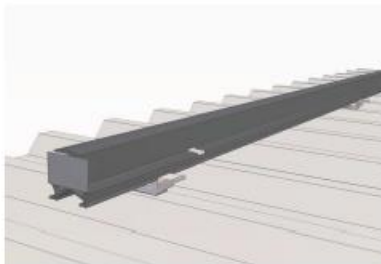
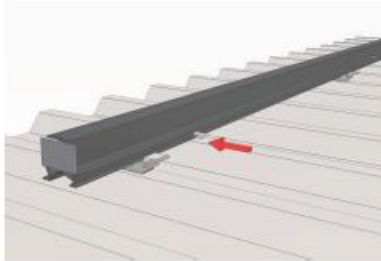

Insert the solar panel into the upper IP insert profile and then lower it into the lower part. Slide the module downwards so that the solar panel is located both above and below in the profile. This way they are held in place by gravity and therefore do not need to be secured further. If the angle is less than 10 degrees, place a rubber fuse at the top between the panels. The next panel can now be slid in and installed, right next to the panel that is already there.



Wognumsebuurt 10, B.O.1.
1817 BH Alkmaar
info@ims-solar.com
www.ims-solar.com
06 - 536 489 71